

THIS DOCUMENT IS THE PROPERTY OF AIRO INDUSTRIES.CO AND IS PROVIDED ON THE EXPRESSED CONDITION THAT IT IS NOT TO BE DISCLOSED REPRODUCED IN WHOLE OR IN PART, OR USED FOR MANUFACTURE BY ANYONE OTHER THAN AIRO INDUSTRIES WITHOUT ITS WRITTEN CONSENT. AND THAT NO RIGHTS PERMITTED TO DISCLOSED OR SO USE ANY INFORMATION CONTAINED IN THIS DOCUMENT

REVISION				
LTR	E.O.	NO.	DATE	APPD
N/C	NEW	RELEASE	07/21/2010	
A	ADD'D INFO & RE -IDENTIFY		08/17/2010	

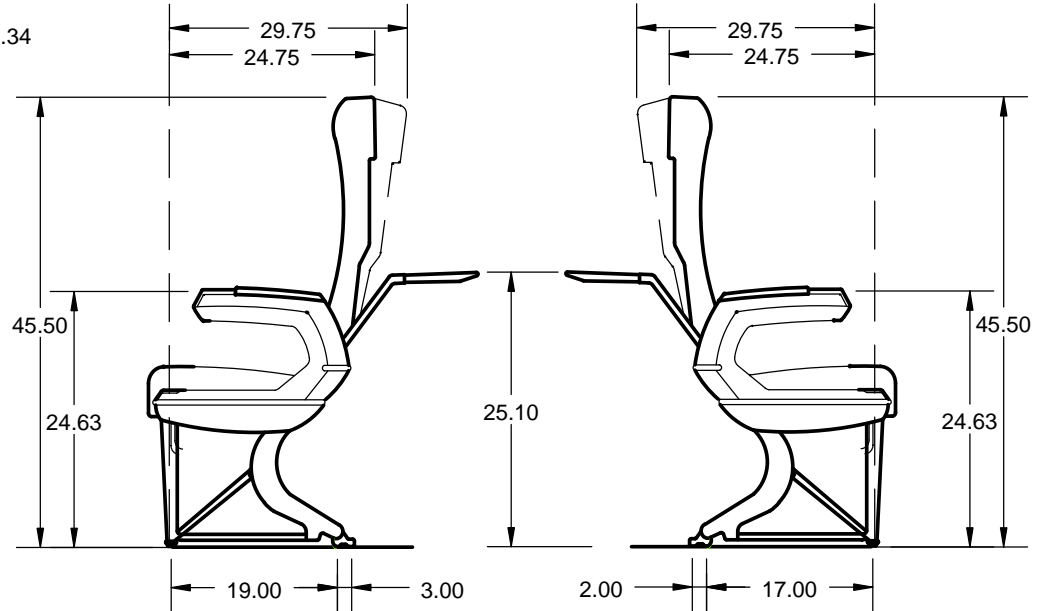
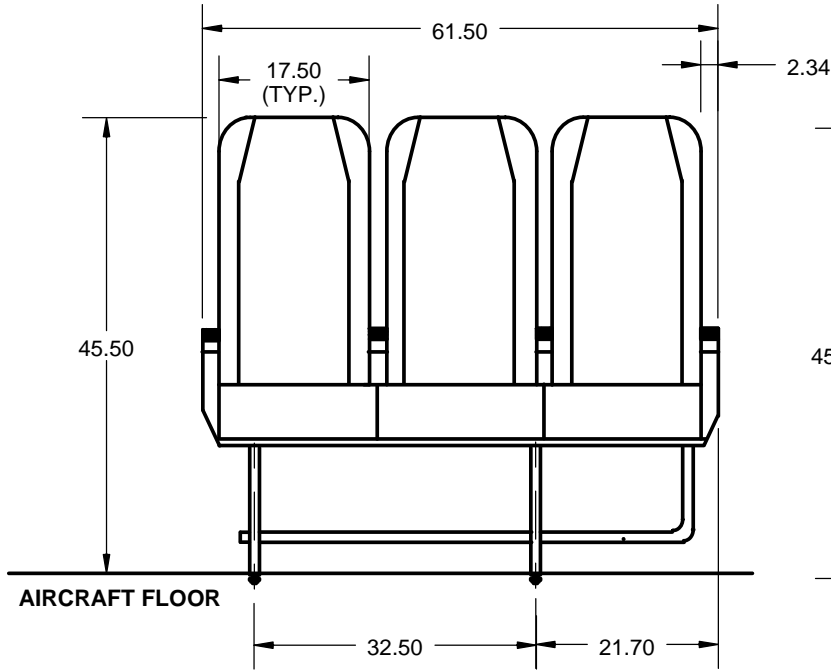

INBOARD VIEW

OUTBOARD VIEW

WAS

1 - SEAT MANUFACTURED BY BE AEROSPACE

NOTE:

REQ,D	PART NO.	NOMENCLATURE	ITEM
UNLESS OTHERWISE SPECIFIED DIMENSIONS ARE IN INCHES .xx = +/- .030 .xxx = +/- .010 ANGLES = +/- 1/2	DRAWN	DATE	AIRO INDUSTRIES, CO 527 JESSIE STREET SAN FERNANDO, CA 91340
	CHECK	DATE	
	ENGRG	DATE	
	MFG ENGRG	DATE	
BREAK ALL SHARP EDGES MARK PART PER ML-STD-130	CONFIG, CNTL	DATE	MODIFICATION BE AEROSPACE R/H SEAT MD83 AIRCRAFT
MACHINED SURFACE FINISHES 126 MAX.	IN LIEU OF	DATE	
		SIZE	DWG NO.
		A	985-PB103x-3RMD
		SCALE NONE	REV A
			SHEET 1 OF 6